

**D**  
ELLIPTICAL HUB  
.25[6.35] WIDE  
X .17[4.32] TALL

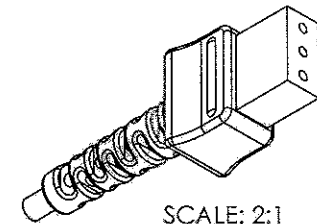
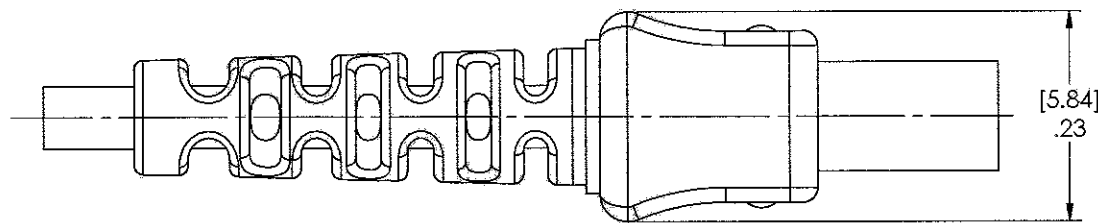
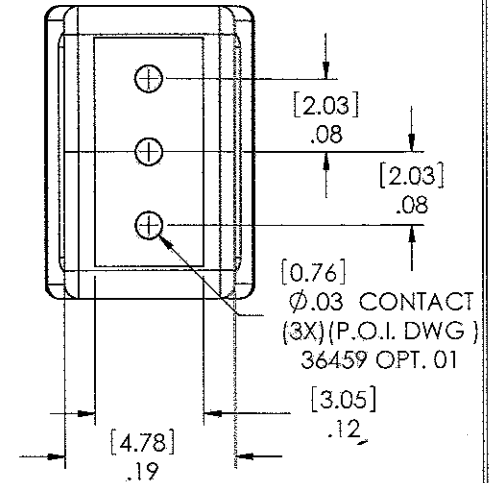
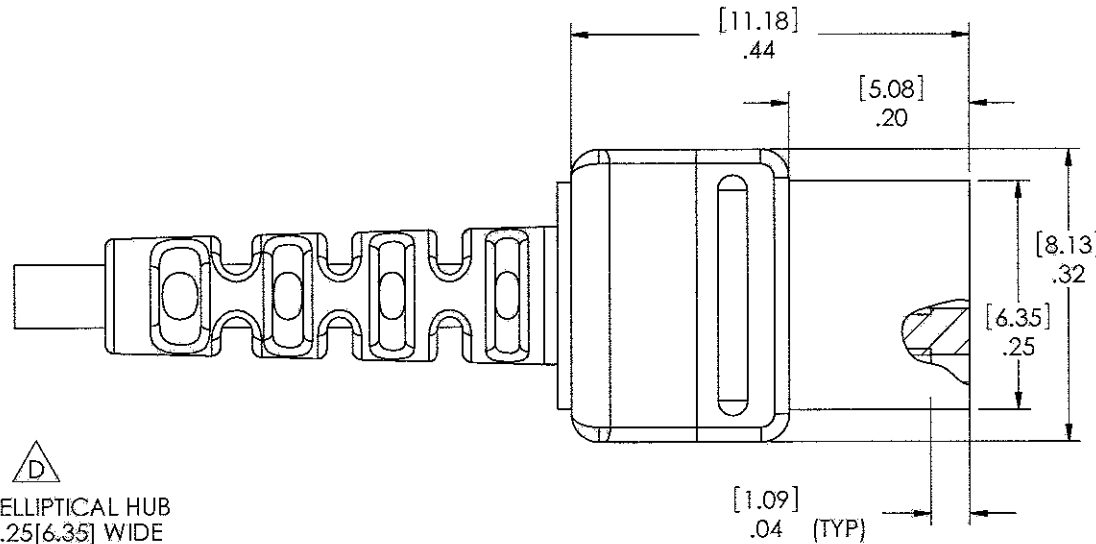

SCALE: 2:1

REV.	DESCRIPTION	APPROVAL DATE	APPROVED BY
D	REV PER ECO 17557 XZ 3/28/12	4/12/12	XZ
C	REV PER ECO 4072 XZ 2/25/99	3/10/99	XZ
B	REV PER ECO 3593 SJ 6/9/98	6/17/98	SJ
A	REL PER ECO 3286 SJ 1/16/98	1/16/98	SJ

**TOLERANCES**  
UNLESS OTHERWISE SPECIFIED  
ALL DIMENSIONS IN INCHES  
DIMENSIONS IN [ ] METRIC

**FRACTIONAL**  
±1/64

**DECIMAL**  
.00 ±.01 [.25mm]  
.000 ±.005 [.127mm]

**ANGULAR**  
±.5°

APPROVALS	DATE
DRAWN JAMISON	12/22/94
CHECKED <i>XZhou</i>	7/10/20
PROJ ENGR	
APPROVED <i>R. Goly</i>	7/14/2020
PROJECT	FSCM

**P Technologies**  
BECAUSE EVERYTHING CONNECTS  
6591 Merriman Road, Roanoke, VA 24018  
Phone: 540-772-7950 Fax: 540-989-7519

TITLE  
RECEPTACLE, 262, 3 PIN

SCALE	5:1
SIZE	DWG
<b>A</b>	2334-50
REV	D
SHT	1 OF 1

THIS DRAWING CONTAINS CONFIDENTIAL AND PROPRIETARY INFORMATION AND MAY NOT BE ISSUED OR REPRODUCED, IN WHOLE, OR IN PART, WITHOUT THE EXPRESS WRITTEN PERMISSION OF P1 TECHNOLOGIES.