

4 | | 3 | | 2 | | 1

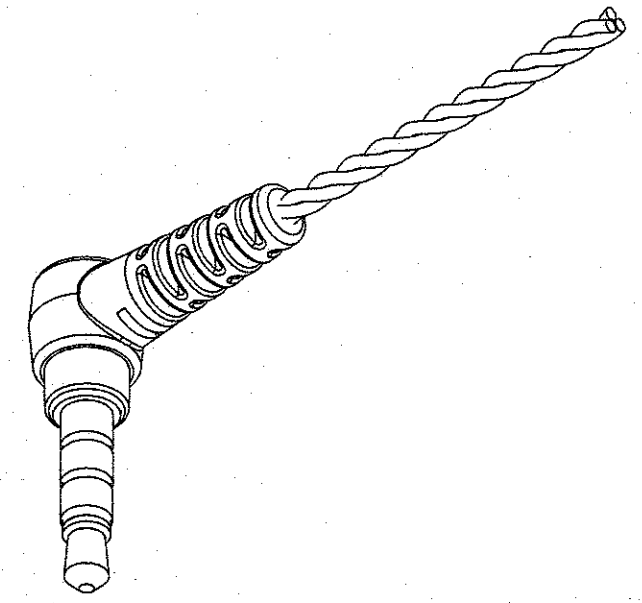
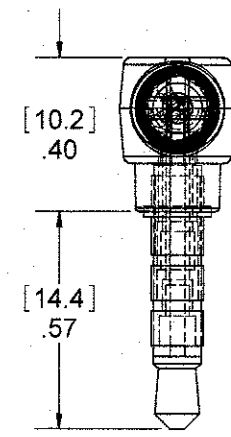
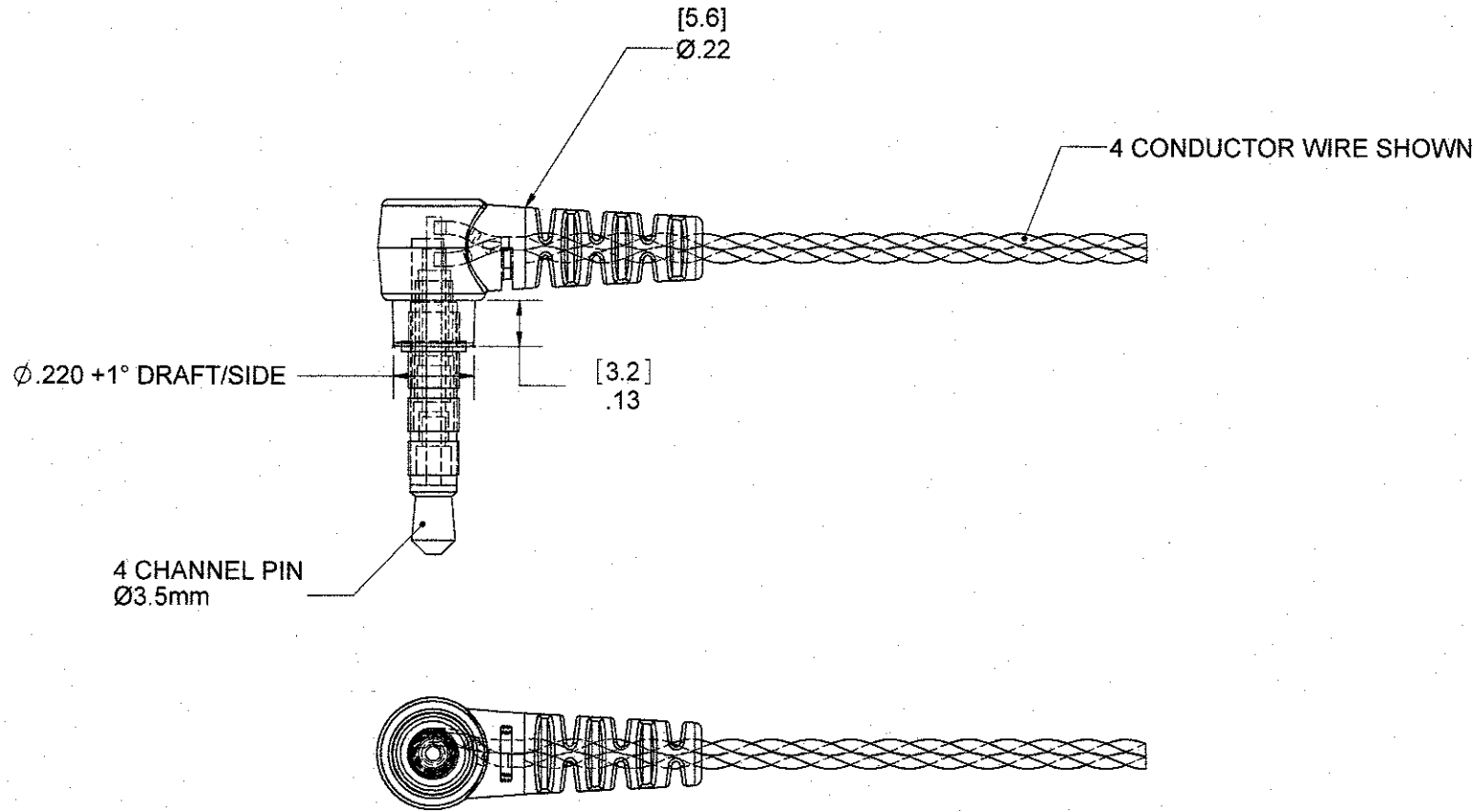
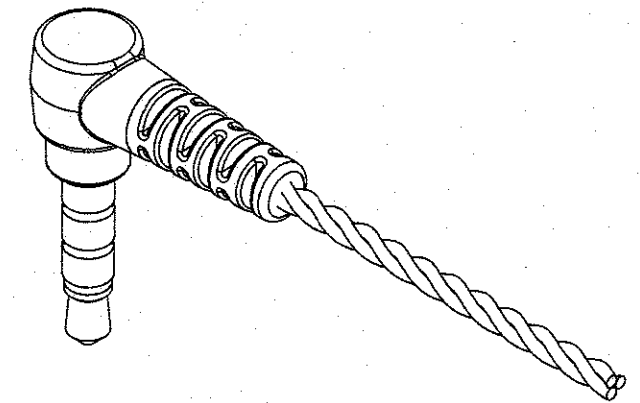
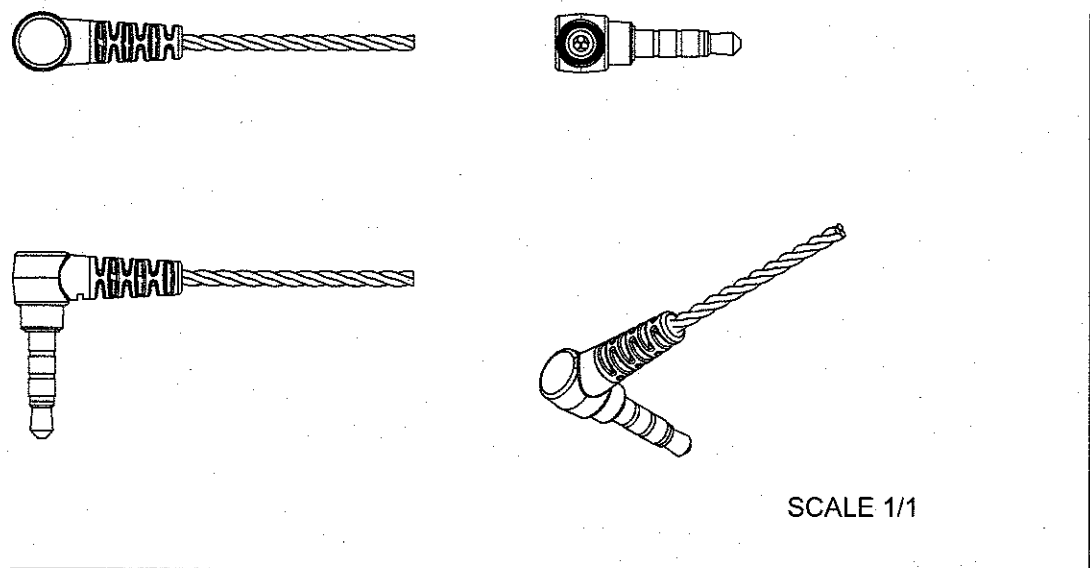

THIS DRAWING CONTAINS CONFIDENTIAL AND PROPRIETARY INFORMATION AND MAY NOT BE ISSUED OR REPRODUCED, IN WHOLE, OR IN PART, WITHOUT THE EXPRESS WRITTEN PERMISSION OF P1 TECHNOLOGIES.

REV	DESCRIPTION	DATE	BY
C	REV PER ECO 11246 JAP 5/15/2008	5/21/08	JB
B	REV PER ECO 11113 JAP 3/4/2008	3/5/08	JAP
A	REL PER ECO 11104 JAP 2/21/2008	2/27/08	JAP
REVISIONS			

TOLERANCES UNLESS OTHERWISE SPECIFIED ALL DIMENSIONS IN INCHES DIMENSIONS IN [] METRIC	
FRACTIONAL ±1/64	
DECIMAL .00 ±.01 [.25mm] .000 ±.005 [.127mm]	
ANGULAR ±.5°	

APPROVALS	DATE
DRAWN J PARKER	2/21/08
CHECKED <i>T. Stump</i>	7/15/20
PROJ ENGR	
APPROVED <i>R. Gopaly</i>	7/16/2020
PROJECT 7535	FSCM

P Technologies
BECAUSE EVERYTHING CONNECTS

6591 Merriman Road, Roanoke, VA 24018
Phone: 540-772-7950 Fax: 540-989-7519

TITLE
PLUG,569, 3.5mm 4 POLE RIGHT ANGLE

SCALE NOTED

SIZE DWG
B 40069-50

REV. SHT
C 1
OF 1

D
—
C
—
B
—
A