

SNAP MED LINKET
WJ0002B

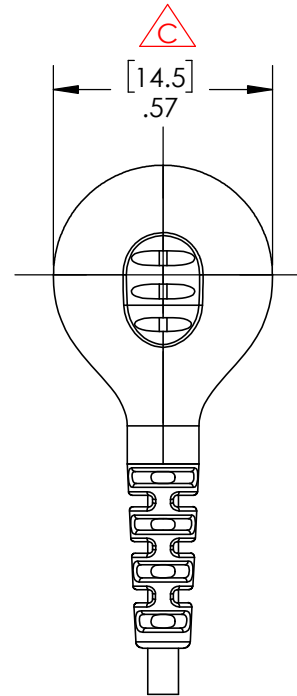

NOTES:

1. MATERIAL: TPE (OTHER MATERIALS AVAILABLE)
2. SIGNAL CONTACT: STEEL
3. GENERAL PERFORMANCE (CONTACT P1 FOR TEST CONDITIONS) LIFE CYCLE: 500 INSERTION CYCLES
EXTRACTION FORCE (FROM STUD): 2-3 LBS
5. OPERATING TEMPERATURE: +5° C to + 60° C
6. UL94 HB
7. DESIGNED FOR DISPOSABLE APPLICATIONS

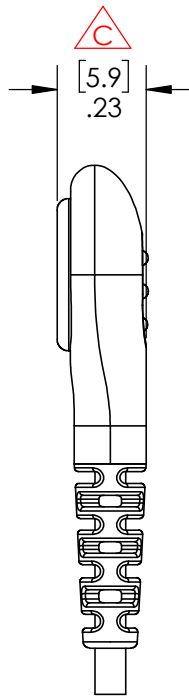
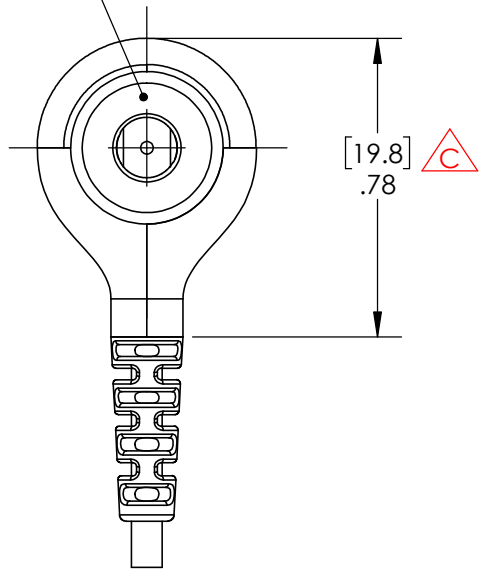
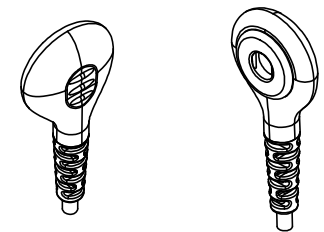

SCALE 1:1

C	REV PER ECO 42744 OEO 1/22/25	SEE ECO # IN POEM	TOLERANCES UNLESS OTHERWISE SPECIFIED ALL DIMENSIONS IN INCHES DIMENSIONS IN [] METRIC	APPROVALS	DATE	 Technologies BECAUSE EVERYTHING CONNECTS 6591 Merriman Road, Roanoke, VA 24018 Phone: 540-772-7950 Fax: 540-989-7519
B	REV PER ECO 30174 XZ 10/26/17	SEE ECO # IN POEM		DRAWN	2/21/17	
A	REL PER ECO 28891 XZ 3/14/17	SEE ECO # IN POEM		CHECKED	2/13/25	
REV	DESCRIPTION	REVISION APPROVALS	FRACTIONAL	PROJ ENGR		TITLE
REVISIONS			±1/64			SNAP, 640
THIS DRAWING CONTAINS CONFIDENTIAL AND PROPRIETARY INFORMATION AND MAY NOT BE ISSUED OR REPRODUCED, IN WHOLE, OR IN PART, WITHOUT THE EXPRESS WRITTEN PERMISSION OF P1 TECHNOLOGIES, INC.			DECIMAL	APPROVED	2/13/25	SCALE 2:1
			.00 ±.01 [.25mm]	T. HOFFMAN		
			.000 ±.005 [.127mm]	PROJECT	FSCM	
			ANGULAR			SIZE DWG
			±.5°			A 42636-50
						REV SHT
						C OF 1